

LCoS

3 panel production convergence station

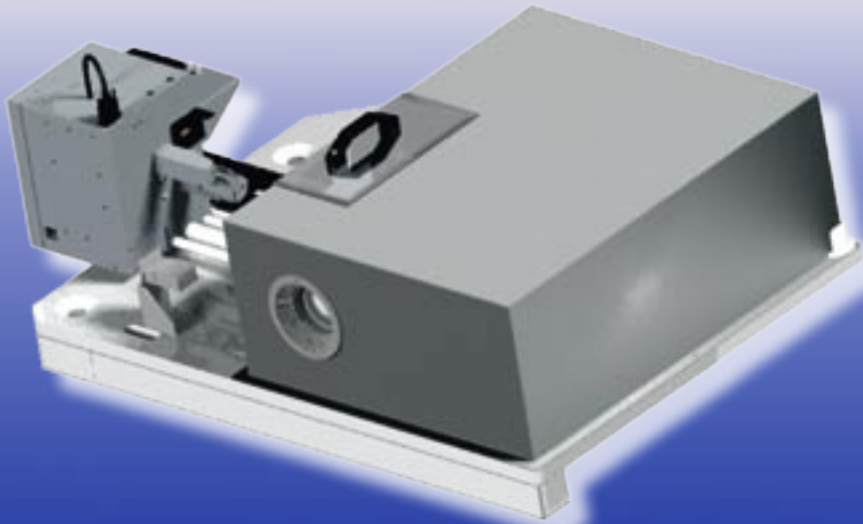

Machine Holder

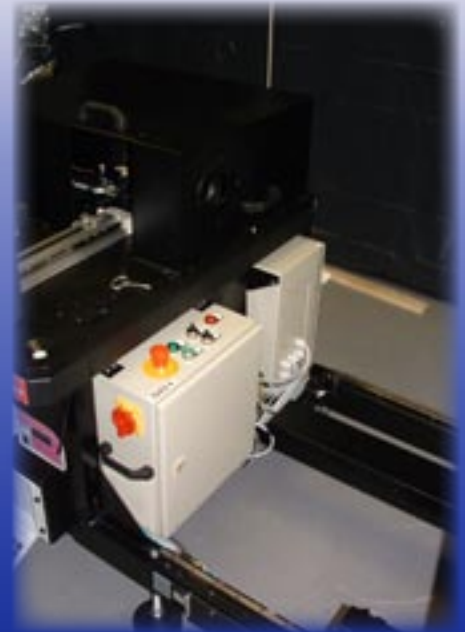

M-Tech developed and manufactured a piece of equipment with the purpose to align and mount 3 LCOS panels onto a color combination system. The color combination system is separated from the actual projection lens. The projection lens and the panel size can vary from time to time. The M-Tech machine is able to handle different types of panel sizes as well as different types of projection sizes and therefore different lens types.

General Equipment Functional Description:

The Assembly system is a pallet-based system. The LCOS kernel is pre-assembled on the pallet with the panels installed and restrained in position. All electrical connections are made at this time and transferred to the driver electronics through a spring pin connector on the pallet. (The pallet itself was a built in for automatic identification.

The assembled pallet will then insert Glue into a semi-automated dispenser. (the Gue-Injection Station). This dispenser will apply the adhesive to the 12 panel retaining pins.

The Convergence station will then be installed into the automated convergence equipment where the panels are sequentially aligned by the M-Tech Six Axis Unit. Data on the kernel convergence characteristics will be written to a database on both the network and hard drive.

The pallet is removed from the equipment and the kernel is removed for subsequent operations. (This unit should be usable for 1, 2, and 3 panel LCOS systems) The

equipment allows the reinsertion of kernels for individual panel replacement and reinstallation.

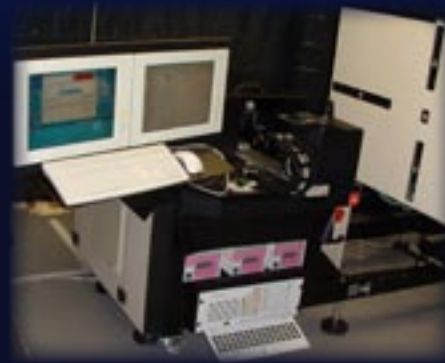

Active curing cycle:

to achieve the best possible convergence the Convergence Station uses an "Active Curing Cycle" to compensate panel movements during the curing process.

The whole curing process is observed by the cameras, if a panel drift is detected a compensation movement is made by the Six Axis Unit to hold the LCOS-panel in position. The active curing process is stopped when the panel is fixed in position.



Glue-Injection Station

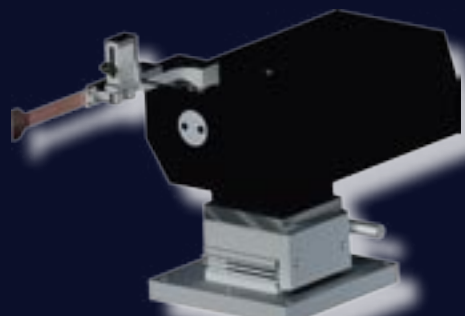

Six Axis Unit

The 3 panel production convergence station construction exists on 8 assemblies.

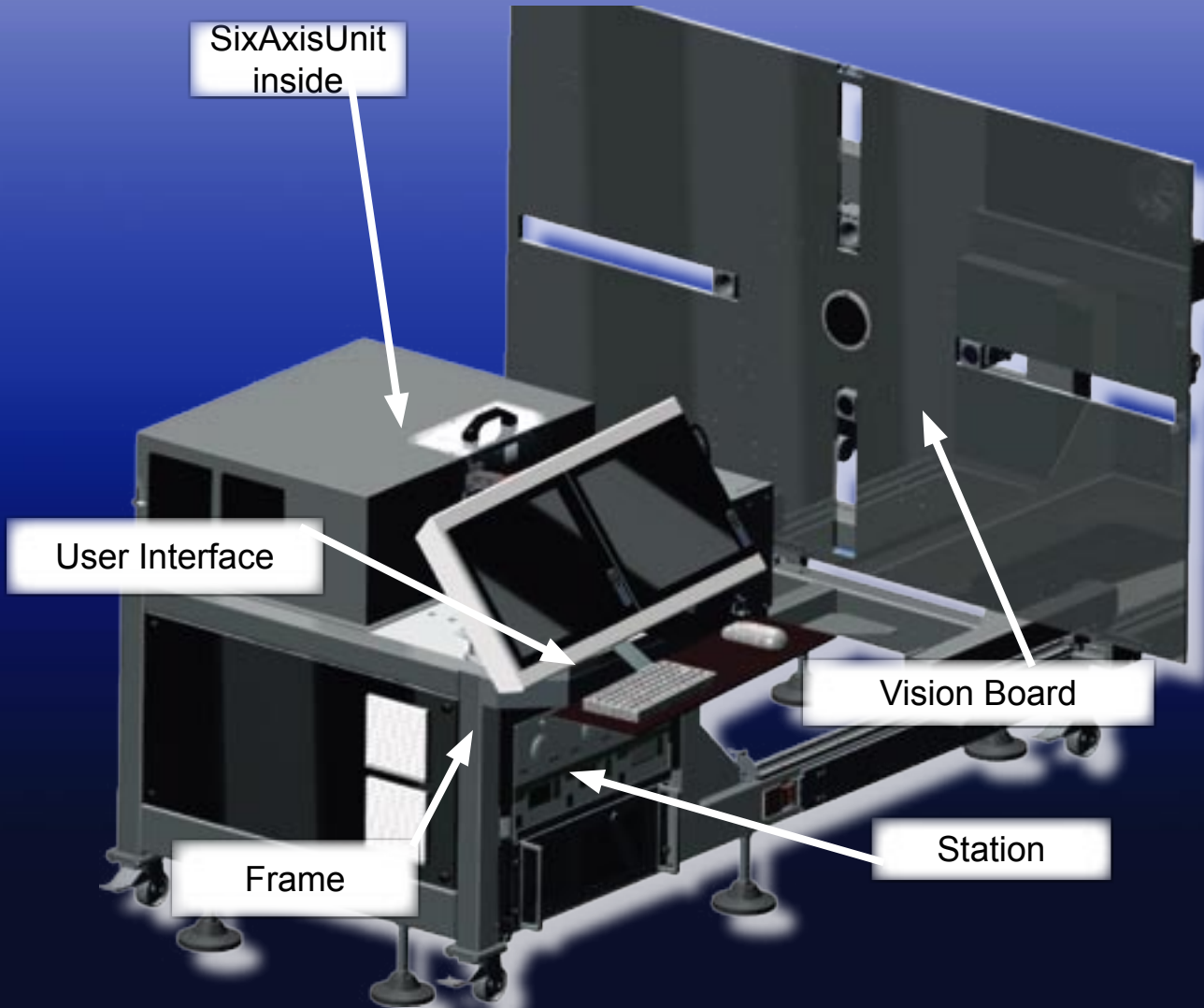

Adjustment Station

The Adjustment Station projects the image of the color combination system to the vision board. It is a stable light flux system.

Six Axis Unit

The panel is gripped by a gripper, which is mounted on the M-Tech Six-AxisUnit. The Six Axis Unit is moving the panel freely in space and finds the focus and convergence automatically.

Machine Frame

It is the basic machine frame. It is a steel structure according to type URA.

Holder

On the holder the optical parts of the light path are mounted. It is the reference plane of the machine.

Vision Board

The Vision Board is a solid metal structure with 4 stages for cameras. One center and 4 motorized CCD cameras are mounted on it.

Power

The power meets EU and US requirements of 220-240VAC, 50 Hertz and 110 VAC, 60 Hertz.

Camera Engine

A stepper engine of Berger Lahr is used to place the cameras on the vision board. The power transmission to the spindle is provided with a coupling. The chosen engine as well as the grade of the threaded spindle guarantees an exact positioning of the camera. The engine is steered over a step engine control.

Vision Board Engine

The Vision Board is motorized with a stepper engine of Berger Lahr for flexible projection distances (600mm to 1000mm).



About M/Tech:

Key facts:

Founded in:	1995
Employees 2005:	60
Turnover 2004:	5 Mio EUR
Subsidiaries:	Vienna, Graz, Linz, Klagenfurt
Exchange 2003:	3 Mio EUR
Business objective:	The customers give the speed of new developments. Our organization is based on flexibility and expertise. That's the fundament for rapid and efficient growth at the beginning of a new technology revolution

M-Tech Fröschl GmbH
Mechanical Engineering and Process Technology
Adi-Dassler-Gasse 2
A-9073 Viktring /Klagenfurt
AUSTRIA/EUROPE
Tel. +43 (463) 432931-0
Fax. +43 (463) 432931-42
Web: <http://www.m-tech.at>
mail: office@m-tech.at

More about 3 panel
convergence station

@

<http://www.m-tech.at>

